



# H5 GSM Alarm System

## Main Features

---

- Capacitive touch buttons, fashion appearance, Without any mechanical contact, long service life.
- Support Access Control System. Swipe card to disarm, Send notification sms about swiping, no need remote. (Optional function)
- Built-in industrial quad band GSM module, globally applicable. Send alarm via voice calling, sms and Contact ID.
- Support 32 wireless and 2 wired zones. 3 detectors for each zone. 8 zone attributes for zone 01-16: Delay, Burglar, Fire, Gas, Duress, Panic and Medical.
- Zone 01-16 name are adjustable.
- Support 8 remote controllers maximum, support home arm, away arm.
- Support 3 program number, for authority management.
- Support arm/disarm in soft voice. With 20s recording.
- Operates on IOS or Android system based smart phone.
- Multi-languages for optional.
- 8 alarm number. Alarm phone type can be set in SMS, dialing or SMS & dialing or center.
- Support door open/closed notification. zone can not arm with the door or window open.
- Support one button calling, two-way communications, SOS button for elderly people.
- Built-in siren, three levels for sound adjustment, support wireless siren.
- Wireless and wired siren prompt for arming/disarming.
- Report of AC and battery power status, on/off optional.
- Arm/disarm report, optional on/off.
- Support remote operation by SMS for arm, disarm, monitoring.
- Support monitoring on-site. One interface for wired siren.
- With arm/disarm timer, can set based on working weekdays and weekends.
- Built-in rechargeable 1250mAh. Standby at least 8 hours.
- Record 30 pieces of latest alarm events. Support to query by date.

## Front of panel

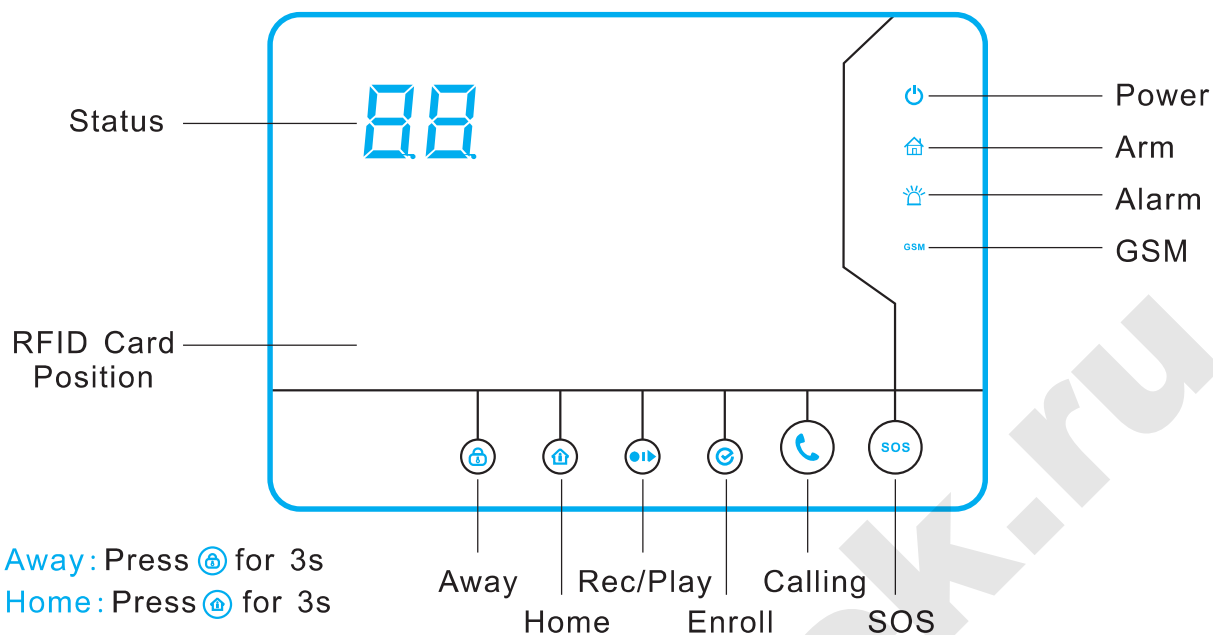

Indicator	light on	light off	Fast flashing	Slow flashing
	AC power	Battery power		Panel or detector battery low power
	Away arm	Disarm		Home arm
	Door open	No alarm	Alarming	
<b>GSM</b>	GSM working		GSM fault/GSM initialization failed	Weak or no signal of GSM

Indicator	Status	Illustration
	Long bright	Arm status
	Long bright	Disarm status
	Fast flashing	Tamper alarm or emergency of remote controller
	Long bright	Door open
	Fast flashing	Zone alarming
	Slow flashing	Detector battery low power

## Back of panel

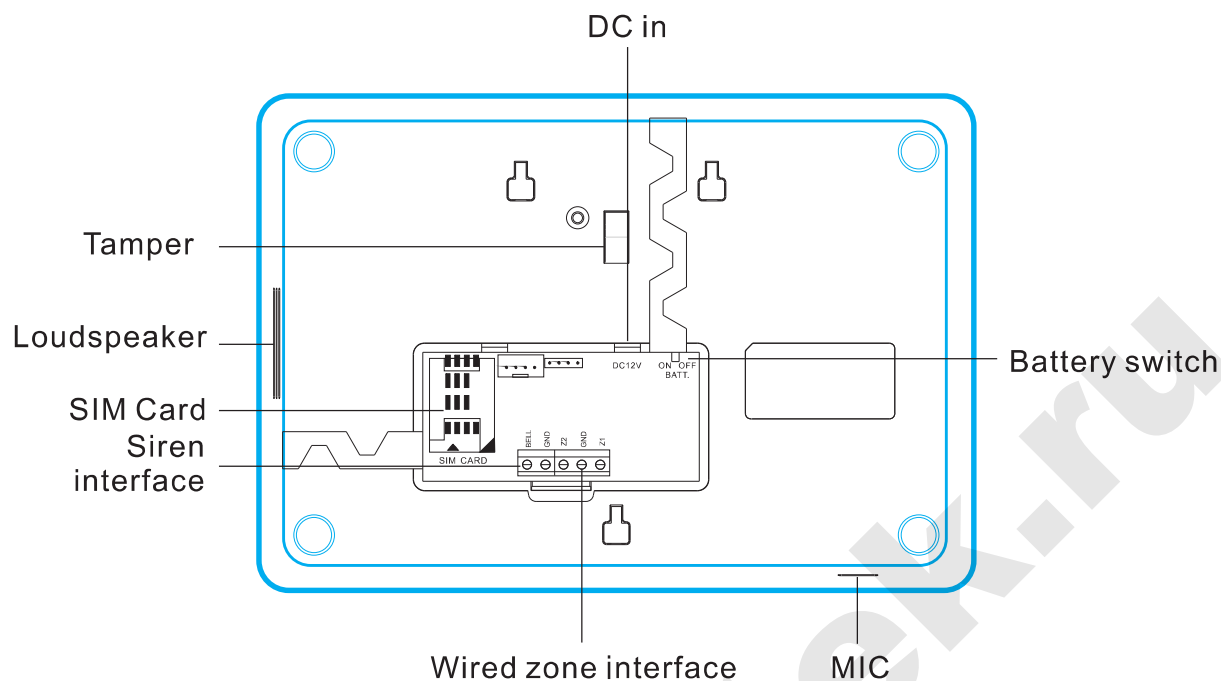

Siren interface:

This interface provide up **DC 12V** for wired siren,warning light,current should be less than **150mA**.Connect the positive side to **BELL** interface and negative side with **GND** interface.

### Wired zone interface

2 wired zone interface,“**Z1 & GND**”&“**Z2 & GND**”, the zone loop should connect with **2.2k resistance**.

### Illustration of beep

Beep	Illustration
A short “Di”	Enroll succeed Arm succeed
A long “Di”	Fault operation The accessory/RFID have been enrolled
Two short “Di”	Correct operation Disarm succeed
A short “Di”per 1s	Arm Delay Alarm delay
A long “Di”per 15s	Detector low power

### 1. Connecting with Contact ID

For connecting with Contact ID, Panels should be set the telephone number type as "CID", and preset CID account in information report.

### 2. RFID report

Users can arm/disarm by RFID card, and panels will send RFID report to preset number.

### 3. Door open/closed setting

#### 3.1 Door open/closed

Users can make door open/closed setting for any zones, to avoid zones be armed when door's open. When door open/closed setting is enable, all doors/windows should be closed to arm.

#### 3.2 Force arm

When users want to arm the zones with open door, it needs to enable the force arm function. Under arm compulsively, the zones with open door are disable. Only the door is closed, the zones will work normally.

# Remote controllers

## 1. Enroll remote controllers

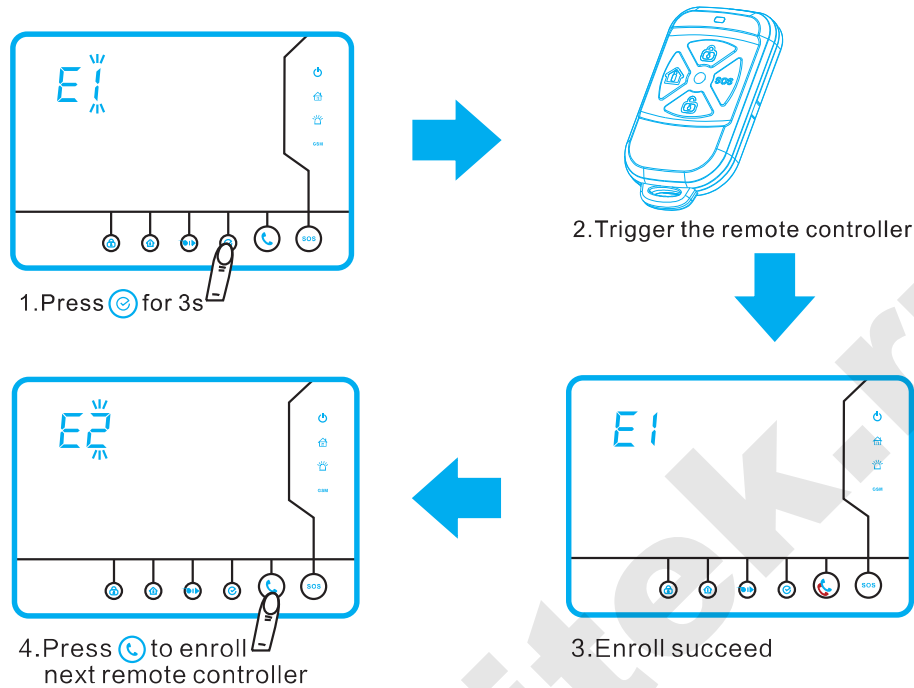

**Note:** if the indicator is long bright, it means this zone has been enrolled, the users have to delete it to enroll another controller  
If hear a long “Di”, it means the remote controller has enrolled already.  
Max 8 remote controllers can be enrolled.

## 2. Delete remote controller

In enrolling status, press  button 3s, to delete the existing remote controller. after two short “Di”, and the indicator is flashing. Delete succeed.

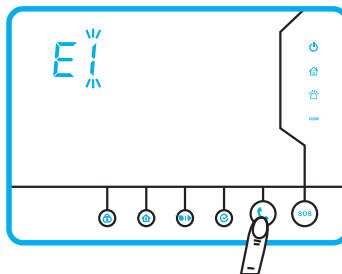

## 3. Exit remote controller enroll

In remote enrolling status, press  3 times to exit.

# Detectors

## 1. Enroll detectors

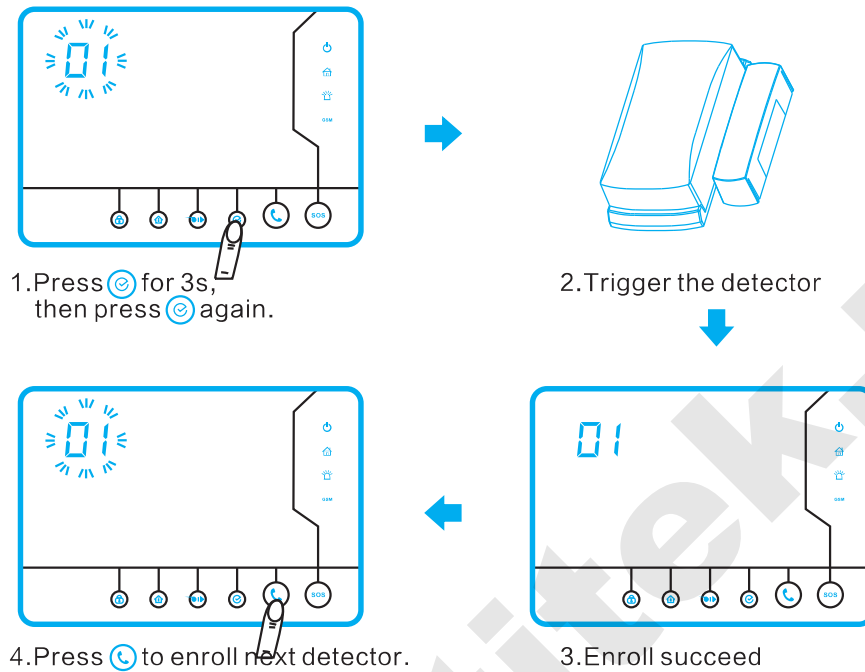

**Note:** If the indicator is long bright, it means this zone has been enrolled, the users have to delete it to enroll another detector.

If hear a long “Di”, it means the detector has been enrolled already.

Max 96 detectors can be enrolled.

## 2. Delete detectors

In detector enrolling status, press  button 3s, to delete the existing detector. After two short “Di” and the indicator is flashing. Delete succeed.

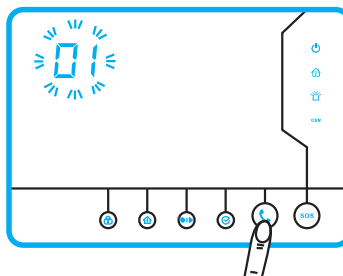

## 3. Exit detector enroll

In detector enroll status, press  button twice to exit.

## 1. Enroll RFID card

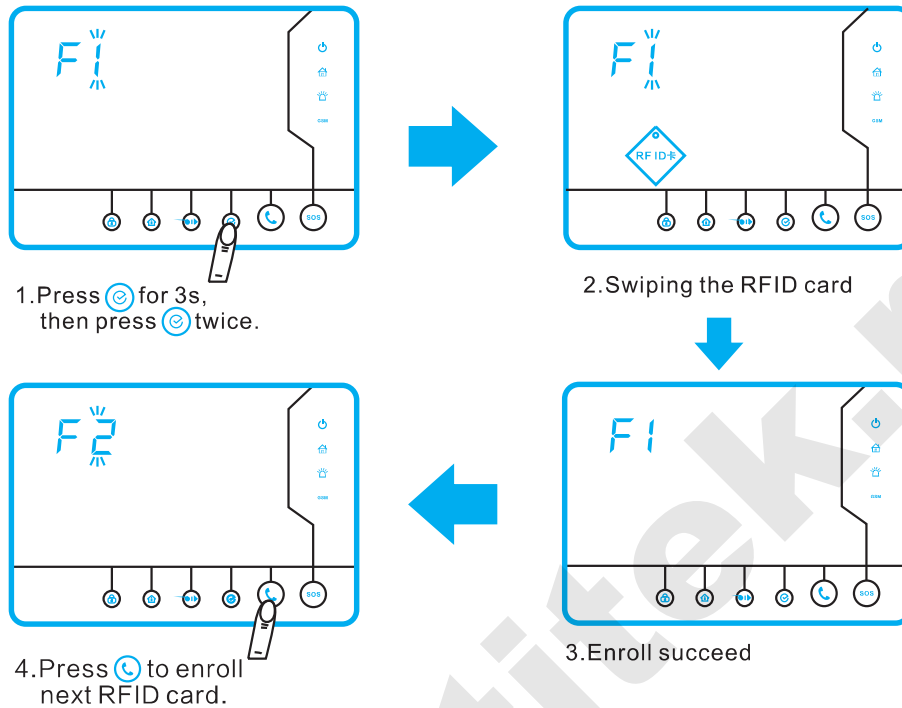

**Note:** If the indicator is long bright, it means this RFID card has been enrolled, the users have to delete it for new enroll.

If hear a long “Di”, it means the RFID card had enrolled already.

Max 4 RFID card can be enrolled.

## 2. Delete RFID card

In RFID enrolling status, press  button 3s, to delete the existing RFID card. after two short “Di” and the indicator is flashing. Delete succeed.

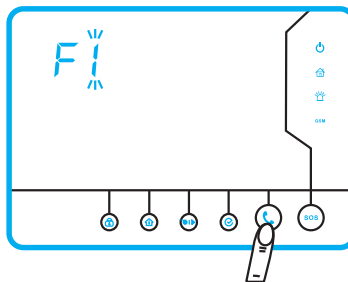

## 3. Exit RFID enroll

In RFID enrolling status, press  to exit.



# Daily operation

## 1. Recording

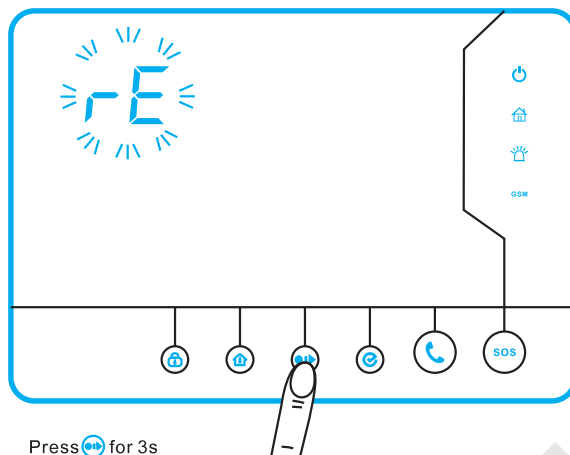

**Note:** The recording lasts 20s.

## 2. Playing

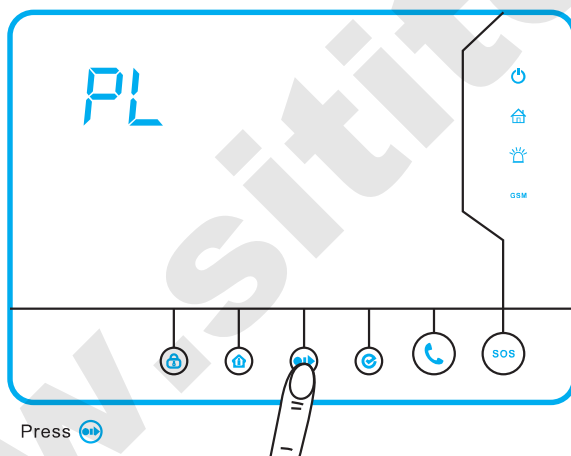

## 3. One button calling

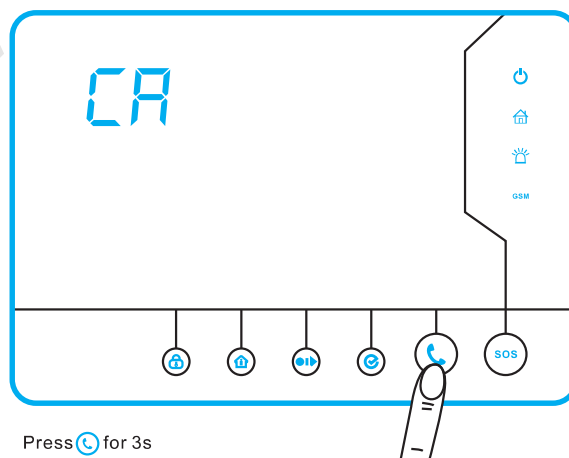

**Note:** If hear a long "Di", means no phone number preset or GSM uninitialized.

## Daily operation

### 1. One button SOS

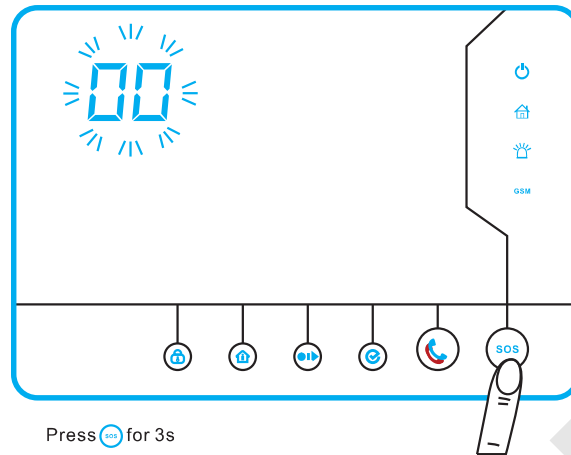

### 2. Query GSM signal

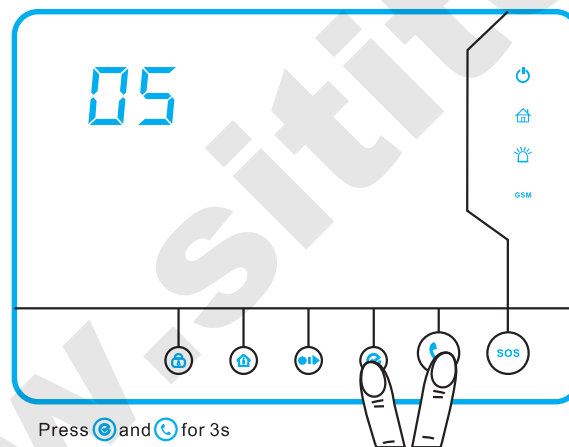

**Note:** The signal level of GSM module is 0-5. 0 means no signal, the signal levels should be over 3 bars for normal working.

# Daily operation

## 1. Recover factory default of accessories and RFID.

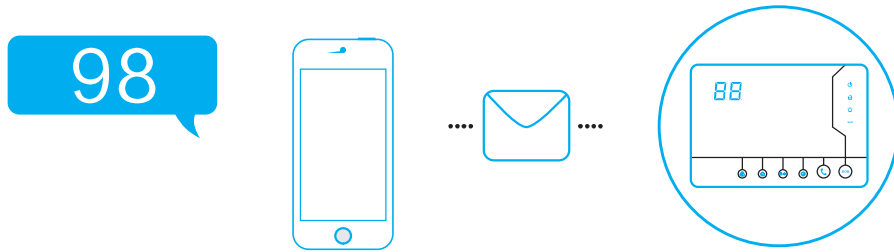

All wireless accessories and RFID card deleted successfully!

## 2. Recover factory default

### 2.1 Keys operation

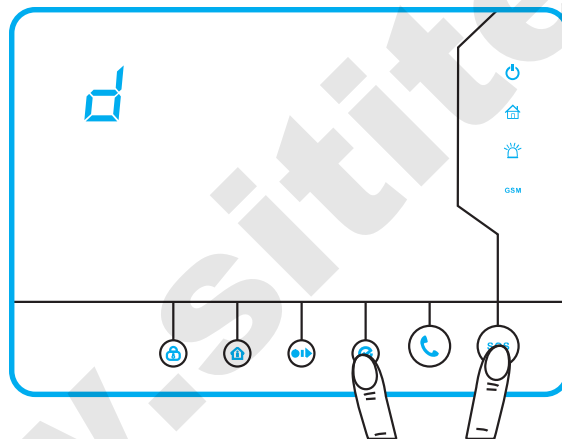

After panel power on, press & in 15s, until hear two short "Di", it means the panel is back to factory default.

### 2.2 SMS operation

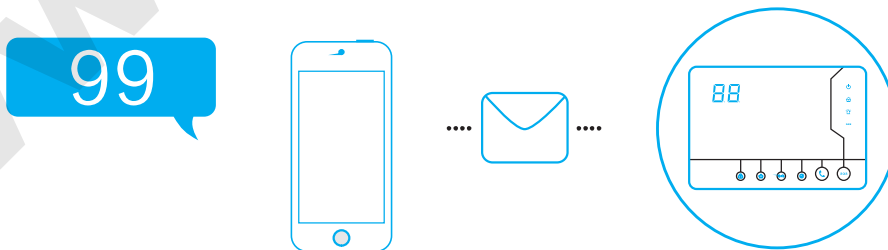

The system has been restored to factory settings!

## Daily operation

### 1. Remote controllers

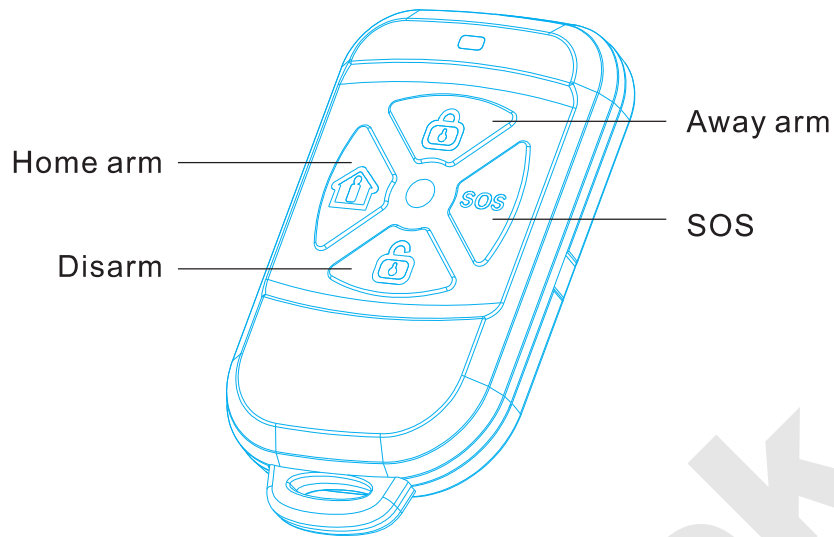

### 2. Arm/Disarm in soft voice

In this status, the voice of panel will weaken. If users want to make soft voice arm/disarm by remote controller, just need to press “Home arm” firstly, and then press “Away arm” or “Disarm”.

### 3. Alarm operation

When alarm phone call, after pick-up, the alarm voice is playing, after the alarm voice you have 5s to input your directives. If there is no respond, the panel will hang up after playing the alarm voice 3 times .

**Note:** When open monitoring, the system will close siren compulsively.

If no operation in 60s, the system will hang up.

Directive	Description	Directive	Description
1#	Away arm	6#	Close siren
2#	Disarm	7#	Open/Close monitoring
5#	Open siren	0#	Hang up

## APP operation

---

### 1. APP installation

Search the key words “H5”, “GSM alarm system”, “alarm” on “APP store” or “Google Play” to download and install.

### 2. Register account

2.1. Enter the APP software.

2.2. Click the “Add Users” button, to edit account information.



2.3. Input “User's Name”, “Panel SIM card No.” then click “OK”.

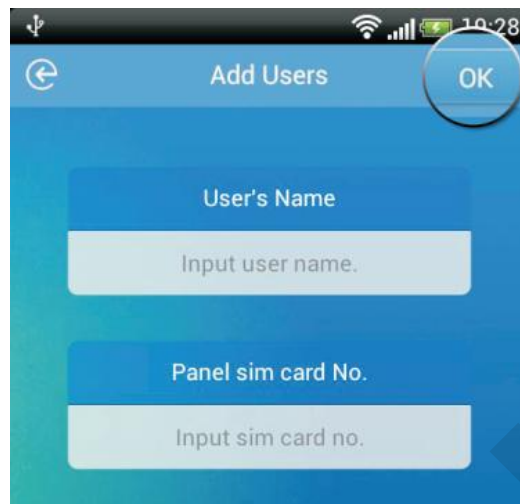

The screenshot shows the 'Add Users' screen. At the top, there is a back arrow, the title 'Add Users', and an 'OK' button. Below the title, there are two input fields. The first is labeled 'User's Name' and contains the placeholder text 'Input user name.'. The second is labeled 'Panel sim card No.' and contains the placeholder text 'Input sim card no.'. The background is a blue gradient.

2.4. On the account list page, click “[User's Name](#)” to make operation and programming. long press “[User's Name](#)” to modify account information.

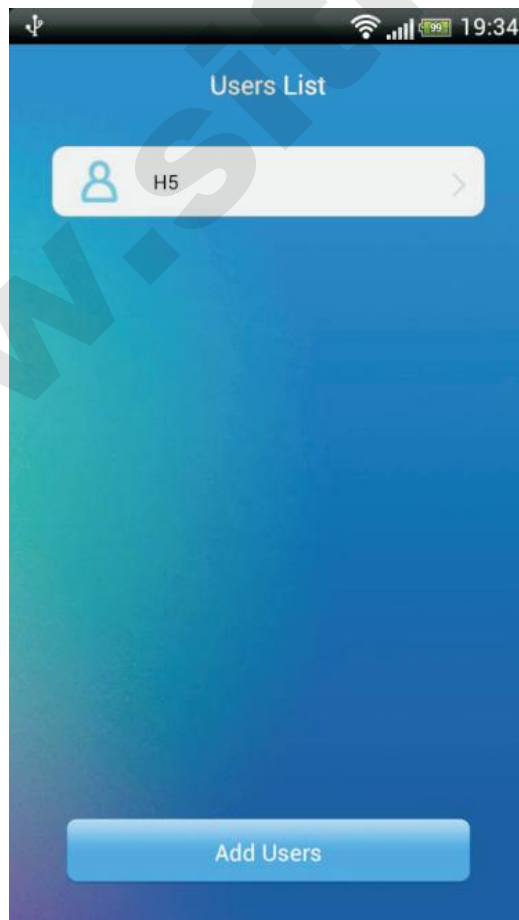

The screenshot shows the 'Users List' screen. At the top, there is a back arrow, the title 'Users List', and the time '19:34'. Below the title, there is a search bar with a person icon on the left, the text 'H5', and a right arrow. At the bottom, there is a blue button labeled 'Add Users'. The background is a blue gradient.

## 1. System language

The alarm system supports multi-languages, users can send sms to choose different language.

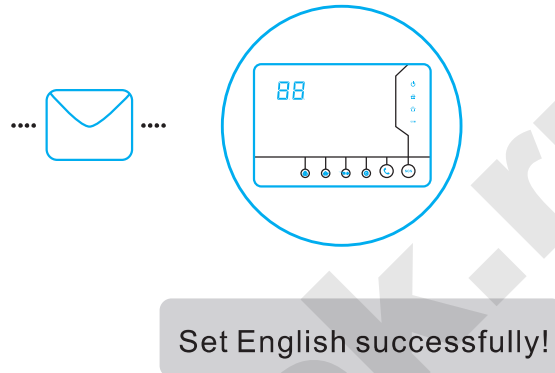

system language	Panel's reply
简体中文	设置简体语言成功!
繁體中文	設置繁體語言成功!
English	Set English successfully!
Tiếng Việt	Thiết lập thành công Việt!
Nederlands	Set Nederlands succes!
Türkçe	Türkçe Ayarlar Başarılı!
Español	Establezca el éxito español

## System operation

### 1. Away arm

After away arm operation, all sensors are armed.



### 2. Home arm

Home arm means user in house, want to arm all sensors outside. Home arm list can be set.



### 3. Disarm

Disarm all sensors, or terminate alarming.

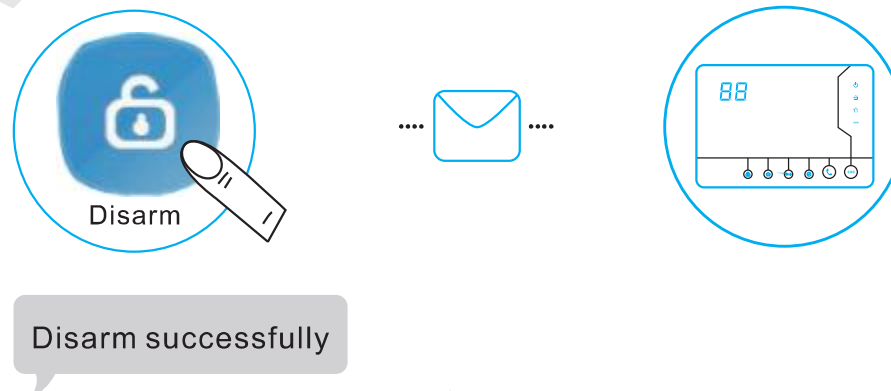



## 1. Monitoring

Users can send monitoring sms to panel, then panel will call back. users can monitor after pick up the calling.



## 2. Open siren

Open built-in siren of panel, wireless siren and wired siren.



## 3. Close siren

Close built-in siren of panel, wireless siren and wired siren.

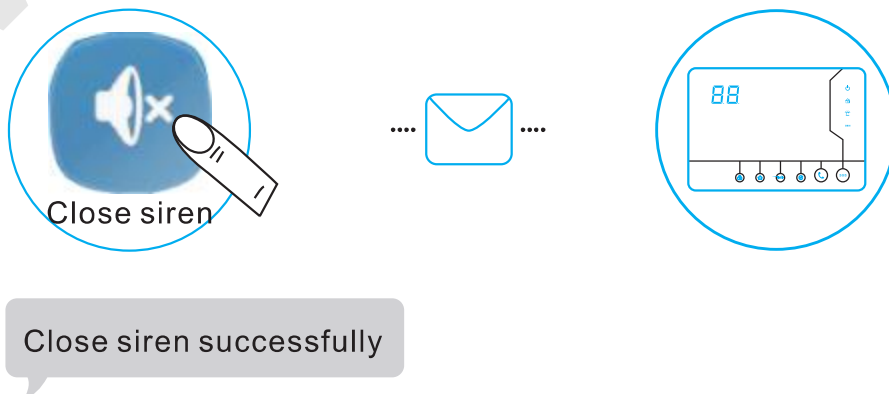

# System operation

## 1. Time calibration

Set time of panel. The panel automatically adopts the time which you sent this directive.



## 2. Status query

Query panel's time and arm/disarm status and other system status.

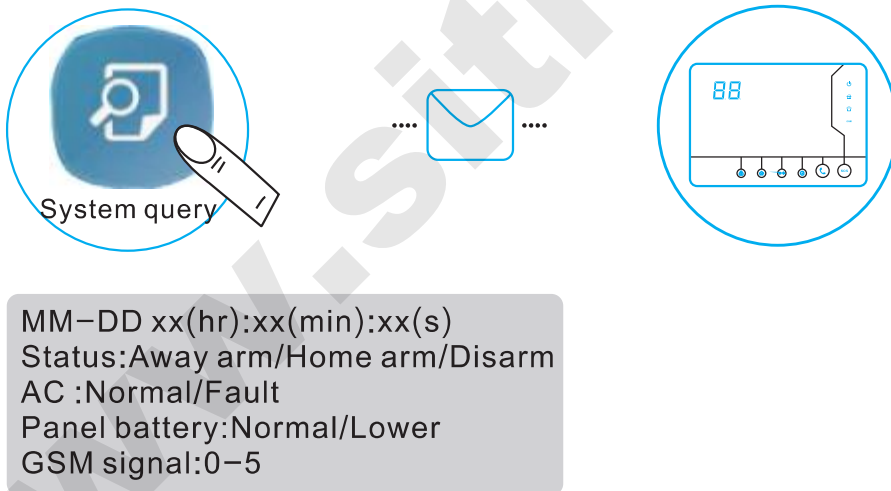

# System programming

## 1. Program & call number

The Program phone number is authorized to program the panel,panels only can be programmed by program phone number.

The call phone number is for two-way communication,which the panel call to user.

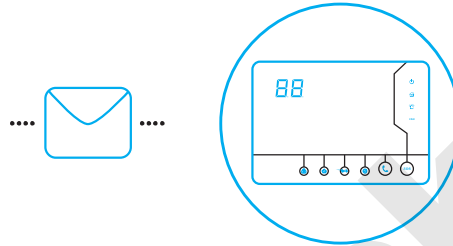

Program & Call phone setting successfully

**Note:** For deleting one of the phone numbers, just need to clear it.

## 2. Alarm phone numbers

When alarm happened,the panel will call preset phone numbers to inform users the alarm event.

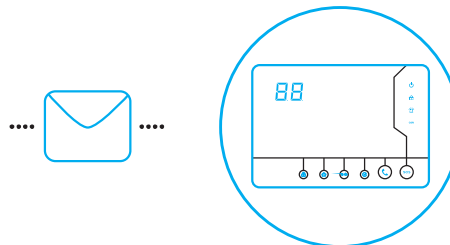

Alarm phone setting successfully

**Note:** For deleting one of the phone numbers, just need to clear it.

## 1. Alarm phone type

The phone number type can be SMS,dialing,SMS & dialing and Contact ID.

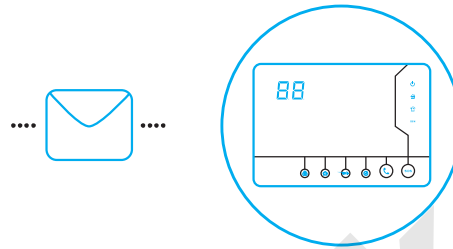
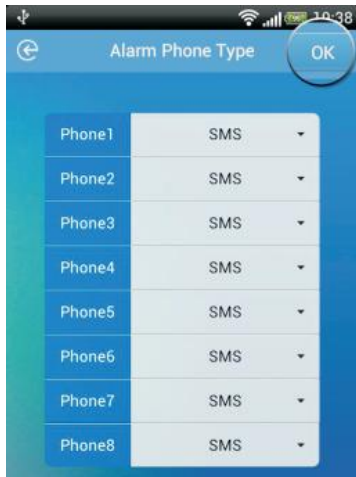

Alarm phone type setting successfully

## 2. Information report

Report type can be SMS,Contact ID ,SMS & Contact ID.

Contact ID Account: Users should get a Contact ID account for connecting with Contact ID.

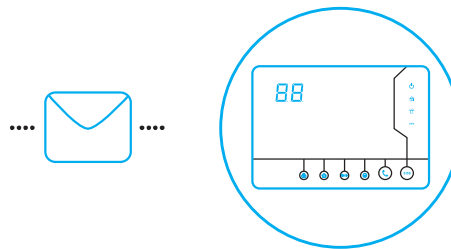
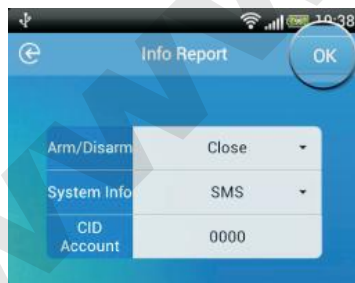

Info report setting successfully

# System programming

## 1. Zone type

Eight zone types for zone 01-16:Delay,burglar,Perimeter,fire,gas, duress,panic and medical. Zone 17-32 are only burglar type.

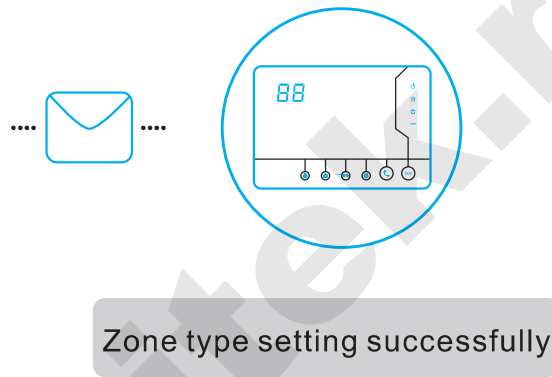

Zone type	Alarm delay	Siren	Arm	Disarm
Delay	√	√	√	×
Burglar	×	√	√	×
Perimeter	×	√	√	×
Fire	×	√	√	√
Gas	×	√	√	√
Silent	×	×	√	√
SOS	×	√	√	√
Medical	×	√	√	√

## 1. Zone name

Zone01-16 can be set a name, such as a detector name, sensor name or location name.

Each name can not be over 15 characters.

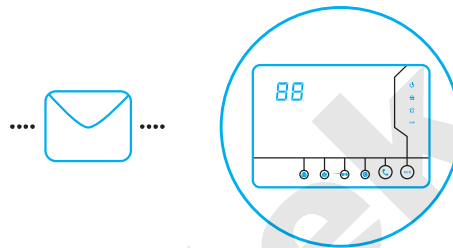

Zone name setting successfully

**Note:** For deleting one of the zone name, only need to clear it.

## 2. Home arm list

Set zone list for home arm.

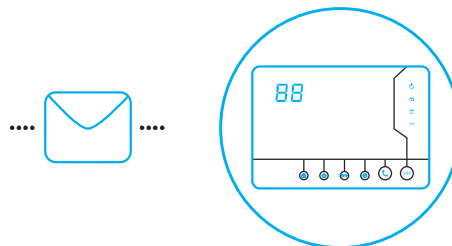

Home arm list setting successfully

# System programming

## 1. Delay time & dial times

Arm delay: The time between arm and the panel in armed status.

Alarm delay: The time range that is from the alarm triggered to the alarm activate.

Dial times: Times for re-dial all alarm phone numbers if no one pick up the phone.

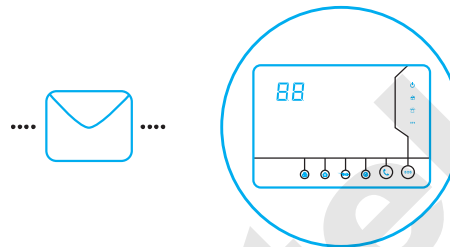
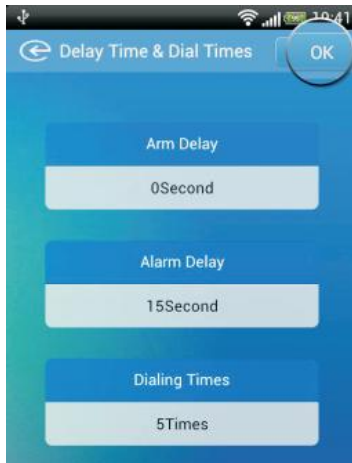

Delay time & dialling times setting successfully

## 2. Siren volume & duration

Three levels volume for built-in siren.

Arm/disarm siren prompt via wireless siren and wired siren.

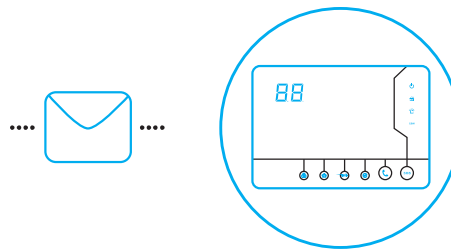
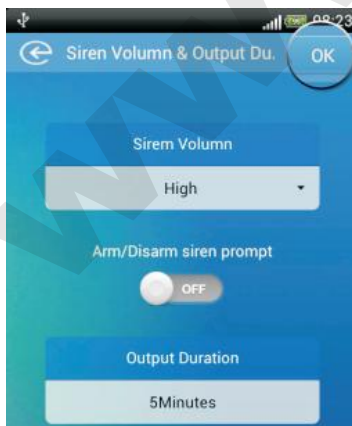

Siren volumn & siren duration setting successfully

## 1. Wireless siren

Wireless siren should be from our company.

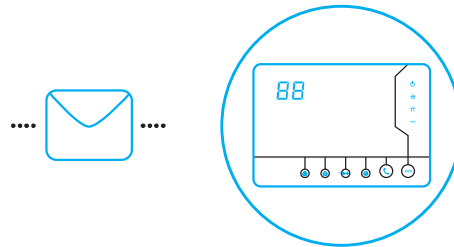

Wireless siren setting successfully

## 2. Arm/disarm timer

Set time and week list for arm/disarm timer.

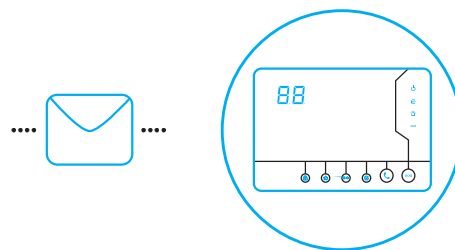
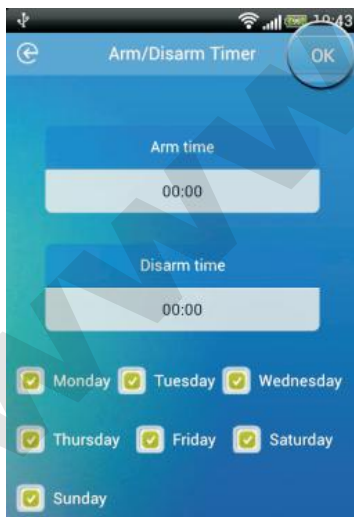

Arm/Disarm timer setting successfully



## 1. Test timer

Panel can notify users or Contact ID periodically, to test if panel works normally.

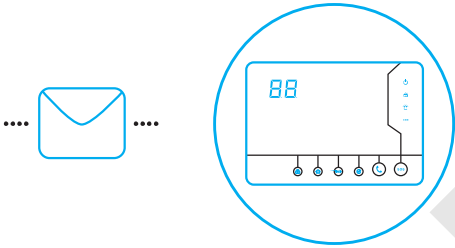
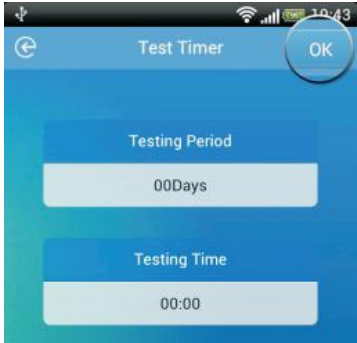

Test timer setting successfully

## 2. Alarm record query

User can query the latest alarm events via date.

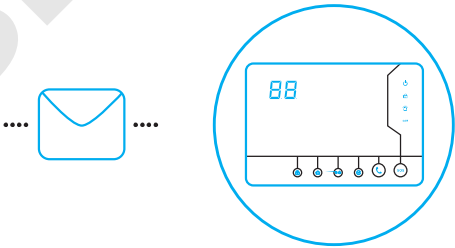
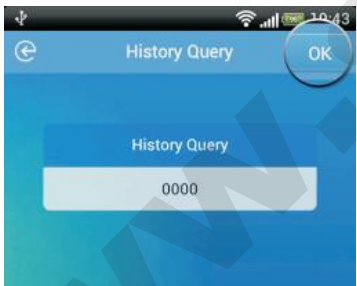

Alarm record

## 1. RFID report number

Set the RFID report number.

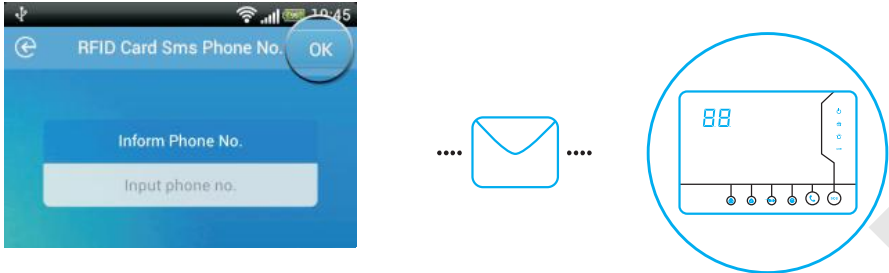

RFID report content"setting successful

Note: For deleting RFID report number, only need to clear it.

## 2. RFID report content.

Set the RFID report content.

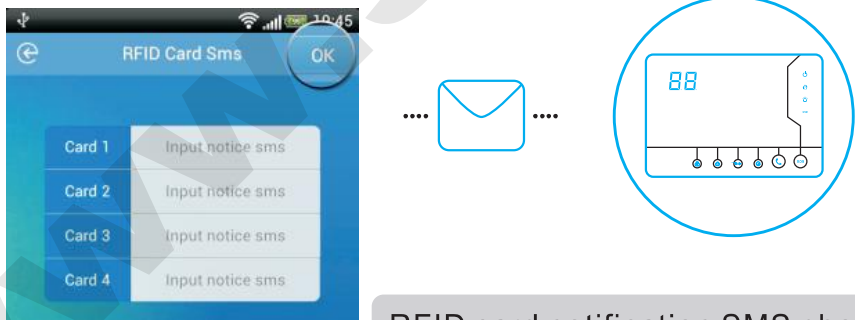

RFID card notification SMS phone setting successfully

Note: For deleting RFID report content, only need to clear it.

1. Door's open/closed setting

Users can select zone list for door's open/closed setting or arm compulsively.

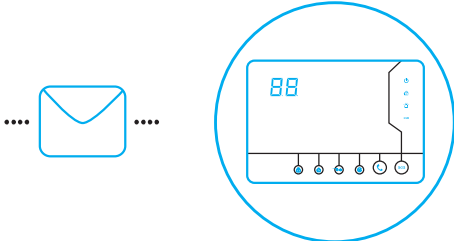

Open door & close door setting successfully

www.Sititeku.ru

### 1. Alarm panel

Size:195mm×136mm×31mm

Power:AC 100V~240V

Battery:7.4V/1250mAh

Output current of wired siren:<150mA

Built-in siren:>90dB(Max & within 1m)

GSM band:850MHz, 900MHz, 1800MHz, 1900MHz

GSM emitting currency:≤2W(850/900MHz), ≤1W(1800/1900MHz)

Wireless working frequency:433/868MHz

Wireless distance:

Between wireless PIR detector and alarm panel:≥400m( in the open area)

Between wireless door sensor and alarm panel:≥200m( in the open area)

Between wireless remote controller and alarm panel:≥100m( in the open area)

Between wireless siren and alarm panel:≥300m( in the open area)

Working temperature: -10℃ - +50℃ humidity: 40 ~ 70%

### 2. Remote controller

Power:Battery CR2016 2pcs

Standby current:≤1uA

Transmitting power: ≤10mW

Transmitting frequency: 433/868MHz

## The limitation of this system

---

While this system is an advanced design security system, it does not offer guaranteed protection against burglar or fire or other emergency. Any alarm systems, whether commercial or residential, is subject to compromise or failure to warn for variety of reasons.

For example:

1. Owing to the omission of the user, the system was not Armed.
2. Misunderstanding on the user's manual by the user or installer causes the abnormal working of the system.
3. Intruders may gain access through unprotected openings or have the technical sophistication to bypass an alarm sensor or disconnect an alarm warning device. Passive Infrared Motion Detectors can only detect intrusion within the designed ranges as diagrammed in their installation manual. They do not provide volumetric area protection. They can not detect motion or intrusion that takes place behind walls, ceiling, floors, closed doors, glass partitions, glass doors, or windows.
4. Passive Infrared Detector sense changes in temperature; however, as the ambient temperature of protected area approaches the temperature range of 32°C to 40°C, the detection performance will decrease.
5. It is exiting no-power or battery-aging.
6. Alarm warning devices such as sirens, bells or horns may not alert people or wake up sleeper if they are located on the other side of closed or partly open doors.
7. Telephone lines needed to transmit alarm signals from a premise to a central monitoring station may be out of service or temporarily out of service. Telephone lines are also subject to compromise by sophisticated intruders.
8. The most common cause of an alarm system not functioning when an intrusion or fire occurs is inadequate maintenance. This alarm system should be tested weekly to make sure all sensors and transmitters are working properly.
9. The wireless communication distance is the testing figure in open area. Please make sure no obstacle in the surrounding environment to guarantee the reliability

## The limitation of this system

---

of the wireless communication distance farther.

10. The weak network signal may be caused by adjusting of carrier, busy network or unavailability of SIM antenna.

11. If you disagree with the above mentioned items, please return the alarm system to our company within 3 days from purchasing. You will get a full refund if the alarm system without artificial damage. Or We take it that you will agree with above items. Installing an alarm system may make one eligible for lower insurance rates, but an alarm system is not a substitute for insurance. Homeowners, property owners and renters should continue to act prudently themselves and continue to insure their lives and property..

[www.sititek.ru](http://www.sititek.ru)

*H5 user manual V1.0*  
20140709