

GRUNDFOS INSTRUCTIONS

# ALPHA2



be think innovate

GRUNDFOS 

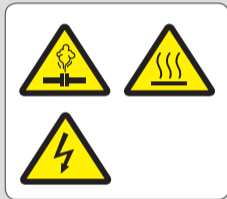



Max. 95 % RH  
IPX4D 



Min./Max.  
+2 °C / +110 °C 

Max. 1.0 MPa  
(10 bar) 

Min./Max.  
0 °C / +40 °C 

< 43 dB(A) 



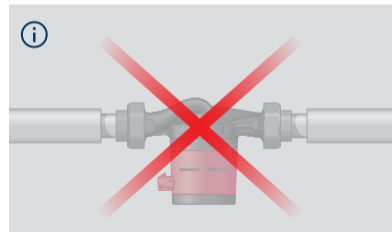
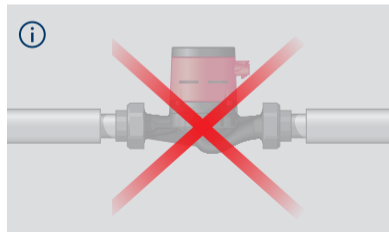
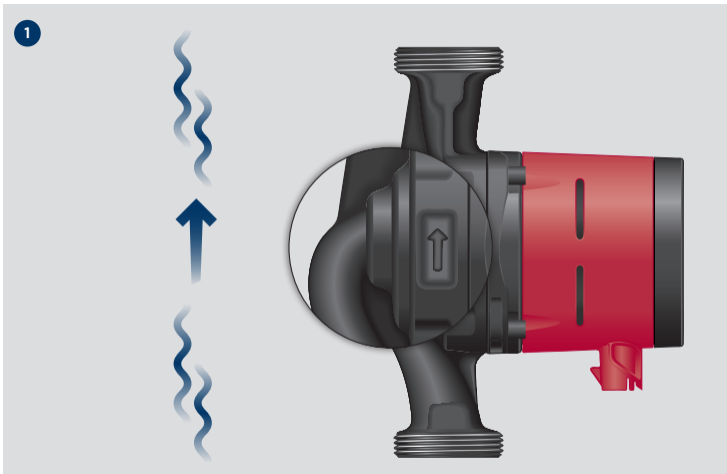

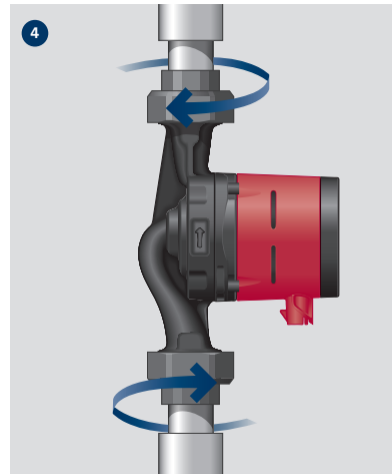
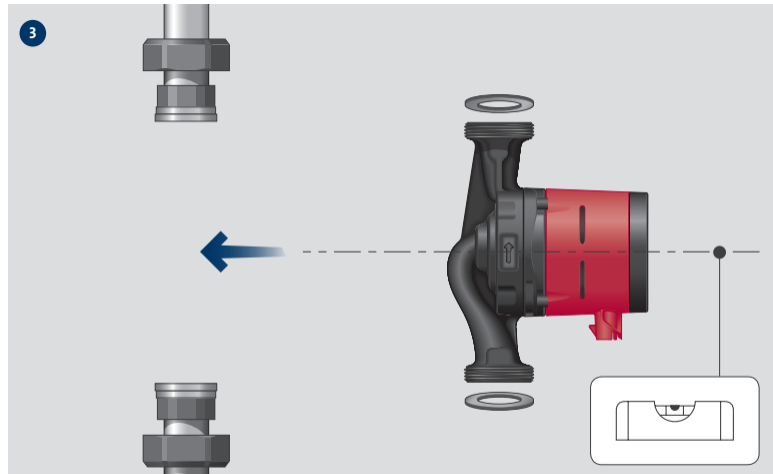
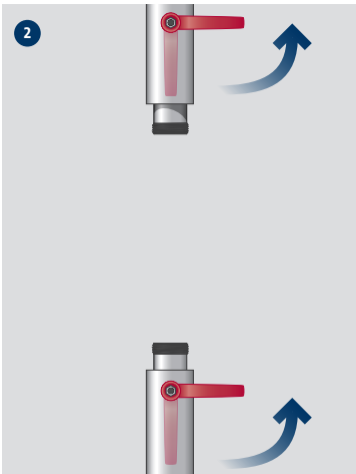

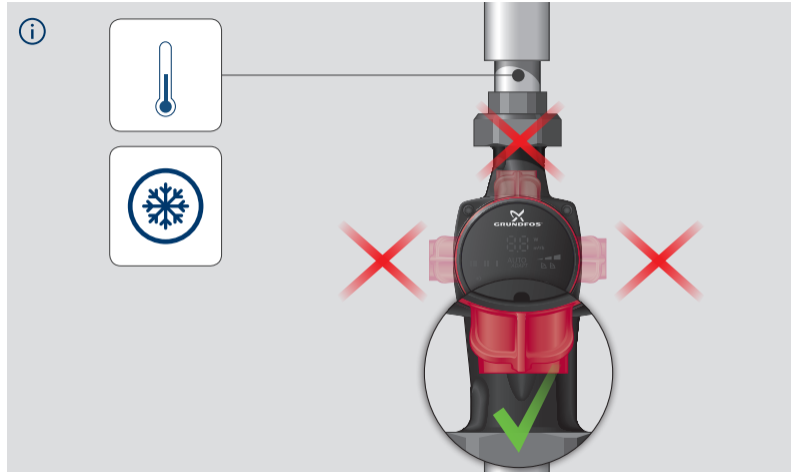
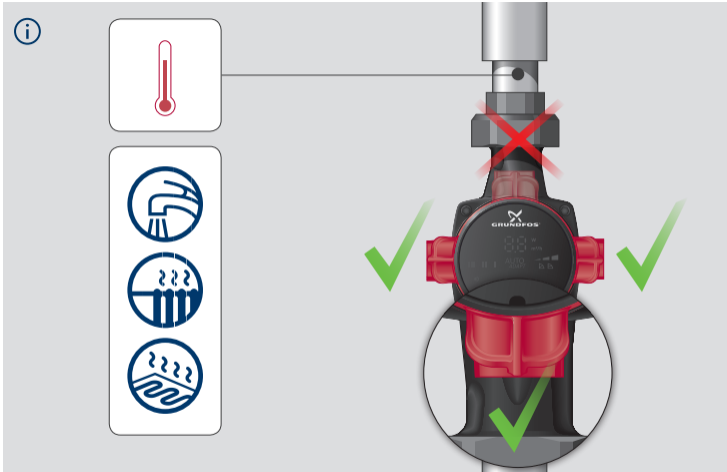

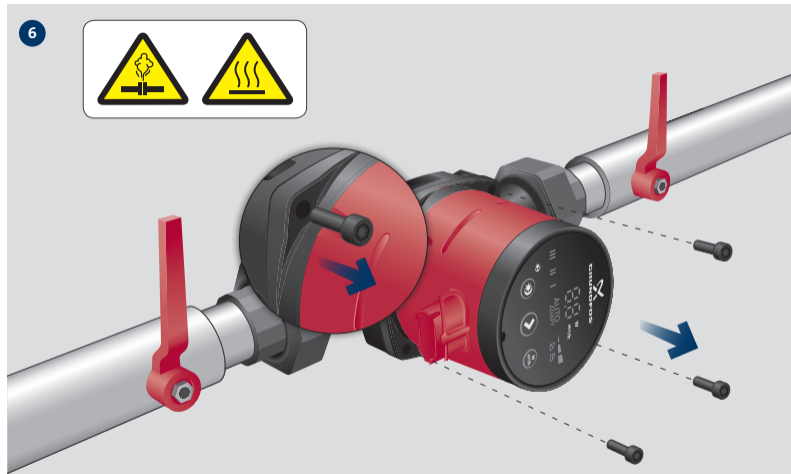
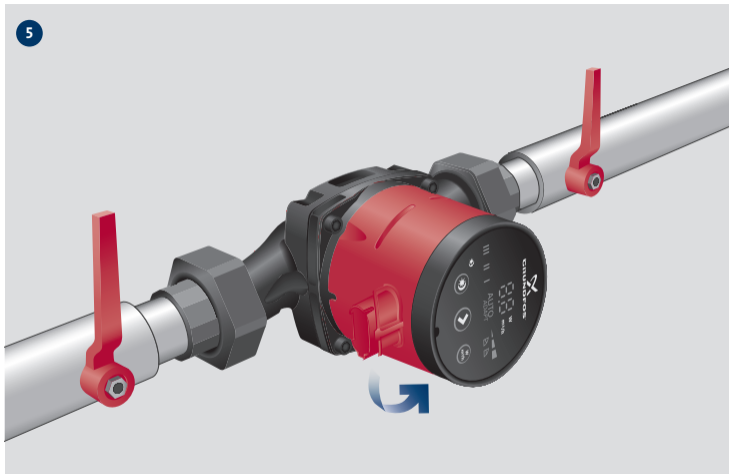

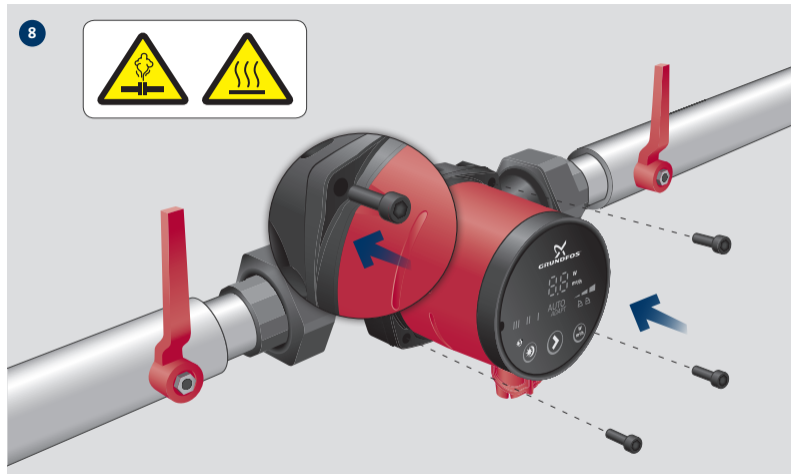
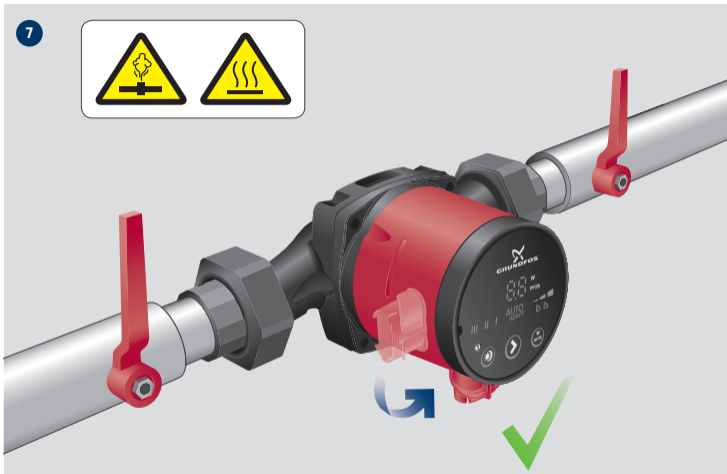

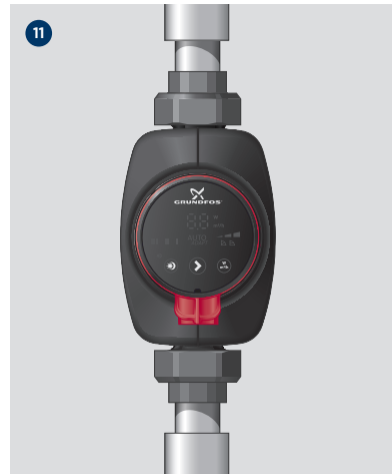



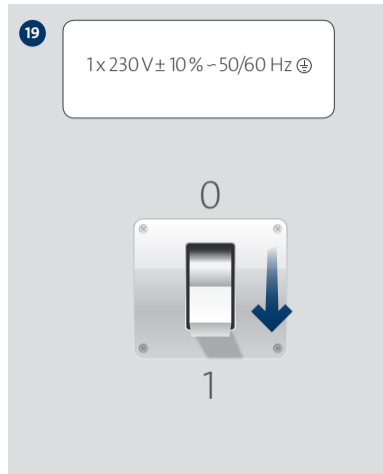
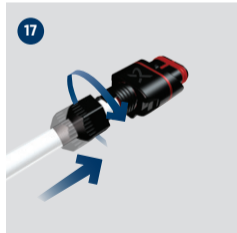
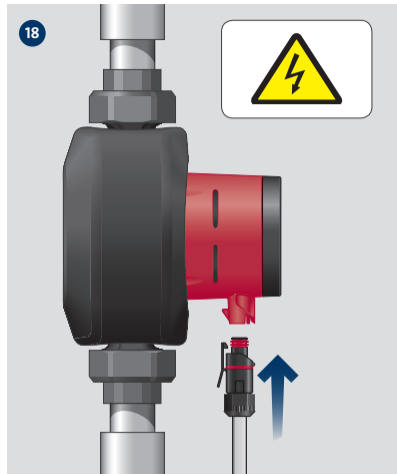
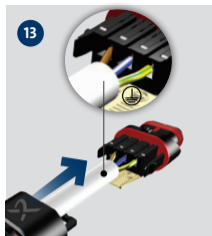
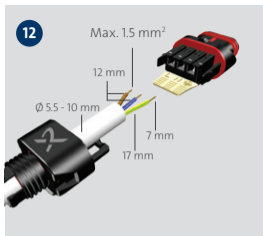



AUTO  
ADAPT

1X



2X



3X



4X



5X



6X



7X



8X



9X



GRUNDFOS.COM/ALPHA2-MANUAL

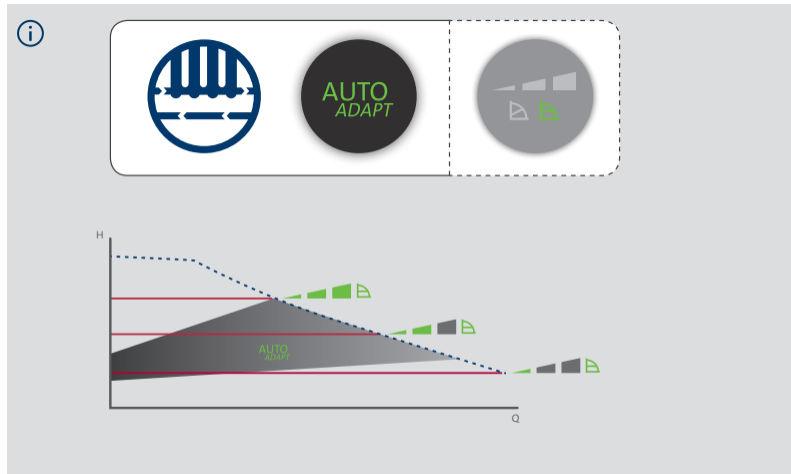
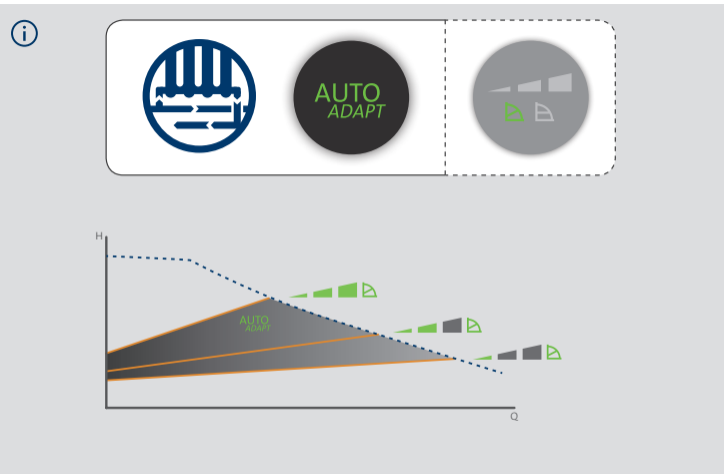



i

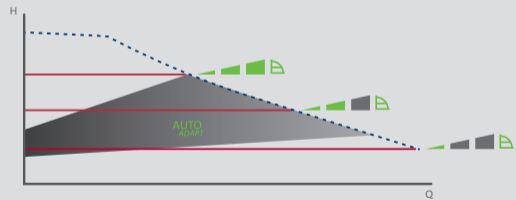
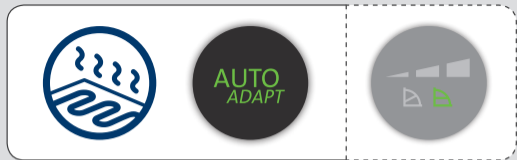

i

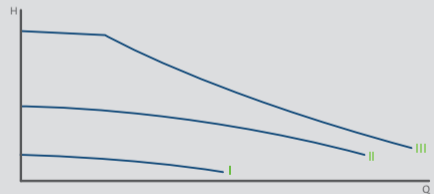
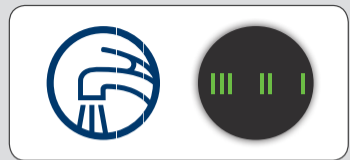

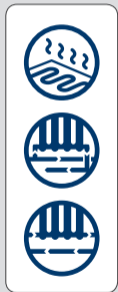

21



[GRUNDFOS.COM/ALPHA2-MANUAL](http://GRUNDFOS.COM/ALPHA2-MANUAL)



22

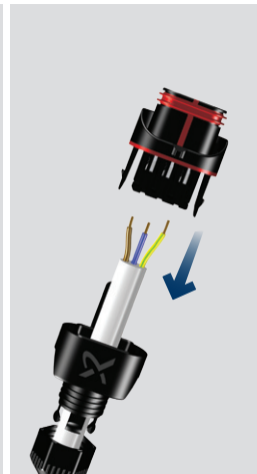
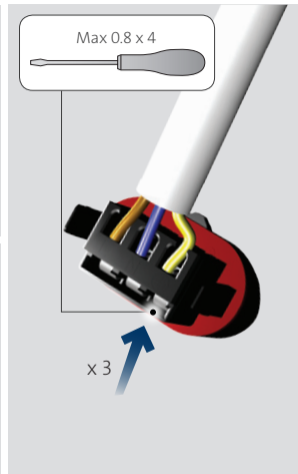
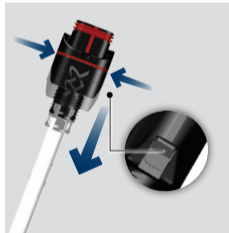
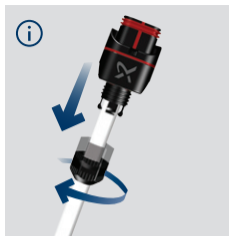



Product No		
25-XX (A)	3/4"	<b>529921</b>
25-XX (A)	1"	<b>529922</b>
32-XX	1"	<b>509921</b>
32-XX	1 1/4"	<b>509922</b>



Product No		
25-XX N	3/4"	<b>529971</b>
25-XX N	1"	<b>529972</b>
32-XX N	1 1/4"	<b>509971</b>



Product No		
25-XX (A)(N)	3/4"	<b>519805</b>
25-XX (A)(N)	1"	<b>519806</b>
32-XX (N)	1 1/4"	<b>503539</b>



Product No		
15-XX	130	<b>98091786</b>
25-XX	130	
25-XX	180	<b>98091787</b>
32-XX	180	



Product No		
25-XX A	180	<b>505822</b>



Product No	
15-XX	<b>98284561</b>
25-XX	
32-XX	

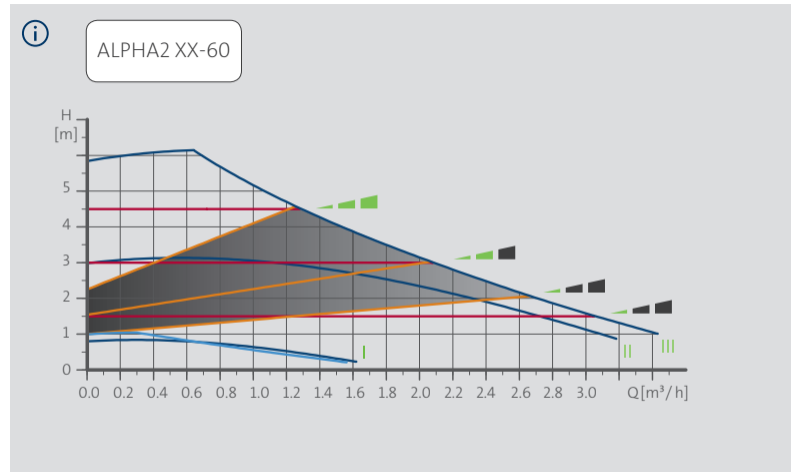
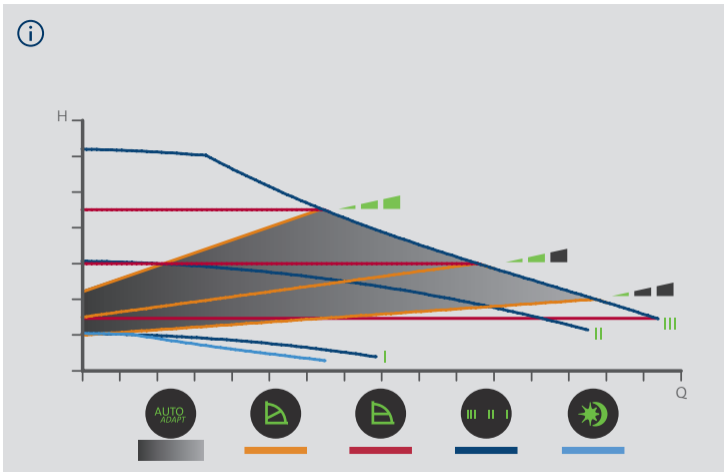





i

ALPHA2 XX-50

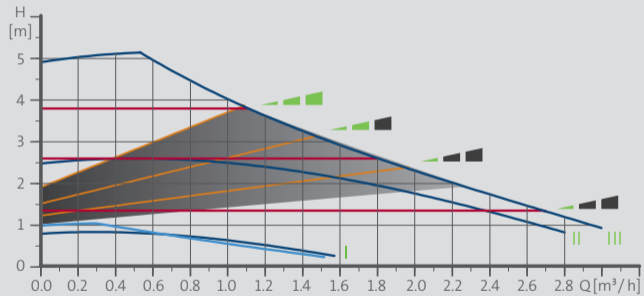

i

ALPHA2 XX-40

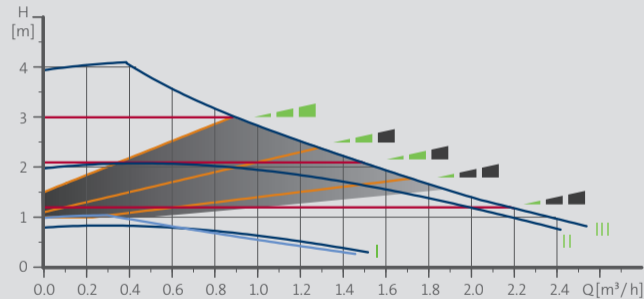

**GB: EC declaration of conformity**

We, Grundfos, declare under our sole responsibility that the product ALPHA2, to which this declaration relates, is in conformity with these Council directives on the approximation of the laws of the EC member states:

**BG: ЕС декларация за съответствие**

Ние, фирма Grundfos, заявяваме с пълна отговорност, че продукта ALPHA2, за който се отнася настоящата декларация, отговаря на следните указания на Съвета за уеднаквяване на правните разпоредби на държавите членки на ЕС:

**CZ: ES prohlášení o shodě**

My firma Grundfos prohlašujeme na svou plnou odpovědnost, že výrobek ALPHA2, na nějž se toto prohlášení vztahuje, je v souladu s ustanoveními směrnice Rady pro sblížení právních předpisů členských států Evropského společenství v oblastech:

**DK: EF-overensstemmelseserklæring**

Vi, Grundfos, erklærer under ansvar at produktet ALPHA2 som denne erklæring omhandler, er i overensstemmelse med disse af Rådets direktiver om indbyrdes tilnærmelse til EF-medlemsstaternes lovgivning:

**EE: EL vastavusdeklaratsioon**

Meie, Grundfos, deklareerime enda ainuvastutusel, et toode ALPHA2, mille kohta käesolev juhend käib, on vastavuses EÜ Nõukogu direktiividega EMÜ liikmesriikide seaduste ühitamise kohta, mis käsitlevad:

**GR: Δήλωση συμμόρφωσης EC**

Εμείς, η Grundfos, δηλώνουμε με αποκλειστικά δική μας ευθύνη ότι τα προϊόντα ALPHA2, στα οποία αναφέρεται η παρούσα δήλωση, συμμορφώνονται με τις εξής Οδηγίες του Συμβουλίου περί προσέγγισης των νομοθεσιών των κρατών μελών της ΕΕ:

**ES: Declaración CE de conformidad**

Nosotros, Grundfos, declaramos bajo nuestra propia responsabilidad que el producto ALPHA2, al cual se refiere esta declaración, está conforme con las Directivas del Consejo en la aproximación de las leyes de los Estados Miembros del EM:

**FR: Déclaration de conformité CE**

Nous, Grundfos, déclarons sous notre seule responsabilité, que le produit ALPHA2, auquel se réfère cette déclaration, est conforme aux Directives du Conseil concernant le rapprochement des législations des Etats membres CE relatives aux normes énoncées ci-dessous :

**HR: EZ izjava o usklađenosti**

Mi, Grundfos, izjavljujemo pod vlastitom odgovornošću da je proizvod ALPHA2, na koji se ova izjava odnosi, u skladu s direktivama ovog Vijeća o usklađivanju zakona država članica EU:

**IT: Dichiarazione di conformità CE**

Grundfos dichiara sotto la sua esclusiva responsabilità che il prodotto ALPHA2, al quale si riferisce questa dichiarazione, è conforme alle seguenti direttive del Consiglio riguardanti il riavvicinamento delle legislazioni degli Stati membri CE:

**LV: EK paziņojums par atbilstību prasībām**

Sabiedrība GRUNDFOS ar pilnu atbildību dara zināmu, ka produkts ALPHA2, uz kuru attiecas šis paziņojums, atbilst šādām Padomes direktīvām par tuvināšanos EK dalībvalstu likumdošanas normām:

**LT: EB atitikties deklaracija**

Mes, Grundfos, su visa atsakomybe pareiškiame, kad gaminys ALPHA2, kuriam skirta ši deklaracija, atitinka šias Tarybos Direktyvas dėl Europos Ekonominės Bendrijos šalių narių įstatymų suderinimo:

**HU: EK megfelelősségi nyilatkozat**

Mi, a Grundfos, egyedüli felelősséggel kijelentjük, hogy a ALPHA2 termék, amelyre jelen nyilatkozik vonatkozik, megfelel az Európai Unió tagállamainak jogi irányműveit összehangoló tanács alábbi előírásainak:

**NL: EC overeenkomstigheidsverklaring**

Wij, Grundfos, verklaren geheel onder eigen verantwoordelijkheid dat het product ALPHA2 waarop deze verklaring betrekking heeft, in overeenstemming is met de Richtlijnen van de Raad in zake de onderlinge aanpassing van de wetgeving van de EG lidstaten betreffende:

**UA: Свідчення про відповідність вимогам ЄС**

Компанія Grundfos заявляє про свою виключну відповідальність за те, що продукт ALPHA2, на який поширюється дана декларація, відповідає таким рекомендаціям Ради з уніфікації правових норм країн - членів ЄС:

**PL: Deklaracja zgodności WE**

My, Grundfos, oświadczamy z pełną odpowiedzialnością, że nasze wyroby ALPHA2, których deklaracja niniejsza dotyczy, są zgodne z następującymi wytycznymi Rady d/s ujednoczenia przepisów prawnych krajów członkowskich WE:

**PT: Declaração de conformidade CE**

A Grundfos declara sob sua única responsabilidade que o produto ALPHA2, ao qual diz respeito esta declaração, está em conformidade com as seguintes Directivas do Conselho sobre a aproximação das legislações dos Estados Membros da CE:

**RU: Декларация о соответствии ЕС**

Мы, компания Grundfos, со всей ответственностью заявляем, что изделия ALPHA2, к которым относится настоящая декларация, соответствуют следующим Директивам Совета Евросоюза об унификации законодательных предписаний стран-членов ЕС:

**RO: Declarație de conformitate CE**

Noi, Grundfos, declarăm pe propria răspundere că produsele ALPHA2, la care se referă această declarație, sunt în conformitate cu aceste Directive de Consiliu asupra armonizării legilor Statelor Membre CE:

**SK: Prehlásenie o konformite EÚ**

My firma Grundfos prehlasujeme na svoju plnú zodpovednosť, že výrobok ALPHA2, na ktorý sa toto prehlásenie vzťahuje, je v súlade s ustanovením smernice Rady pre zblíženie právnych predpisov členských štátov Európskeho spoločenstva v oblastiach:

**SI: ES izjava o skladnosti**

V Grundfosu s polno odgovornostjo izjavljamo, da so naši izdelki ALPHA2, na katere se ta izjava nanaša, v skladu z naslednjimi direktivami Sveta o približevanju zakonodaje za izenačevanje pravnih predpisov držav članic ES:

**RS: EC deklaracija o konformitetu**

Mi, Grundfos, izjavljujemo pod vlastitom odgovornošću da je proizvod ALPHA2, na koji se ova izjava odnosi, u skladu sa direktivama Saveta za usklađivanje zakona država članica EU:

**FI: EY-vaatimusten mukaisuus- vakuutus**

Me, Grundfos, vakuutamme omalla vastuullamme, että tuote ALPHA2, jota tämä vakuutus koskee, on EY:n jäsenvaltioiden lainsäädännön yhdenmukaistamiseen tähtäävien Euroopan neuvoston direktiivien vaatimusten mukainen seuraavasti:

**SE: EG-försäkran om överensstämmelse**

Vi, Grundfos, försäkrar under ansvar att produkten ALPHA2, som omfattas av denna försäkran, är i överensstämmelse med rådets direktiv om inbördes närmande till EU-medlemsstaternas lagstiftning, avseende:

**TR: EC uygunluk bildirgesi**

Grundfos olarak bu beyannameye konu olan ALPHA2 ürünlerinin, AB Üyesi Ülkelerin kanunlarını birbirine yaklaştırma üzerine Konsey Direktifleriyle uyumlu olduğunun yalnızca bizim sorumluluğumuz altında olduğunu beyan ederiz:

Low Voltage Directive (2006/95/EC).  
Standard used: EN 60335-2-51: 2003.  
EMC Directive (2004/108/EC).  
Standards used: EN 55014-1: 2006 and EN 55014-2: 1997.  
Ecodesign Directive (2009/125/EC).  
Circulator pumps:  
Commission Regulation No 641/2009.  
Standards used: EN 16297-1: 2012 and EN 16297-2: 2012.

Bjerringbro, 1st September 2011

Jan Strandgaard  
Technical Director  
Grundfos Holding A/S  
Poul Due Jensens Vej 7  
DK-8850 Bjerringbro  
Denmark

This EC declaration of conformity is only valid when published and distributed as part of the Grundfos installation and operating instructions.

**GB: Warning**

The use of this product requires experience with and knowledge of the product. Persons with reduced physical, sensory or mental capabilities must not use this product, unless they are under supervision or have been instructed in the use of the product by a person responsible for their safety. Children must not use or play with this product.

**BG: Предупреждение**

Използването на този продукт изисква познание и опит в работата с този продукт. Хора с намалени физически, осезателни или умствени способности не трябва да използват този продукт, ако не са под наблюдение или не са инструктирани относно използването на продукта от човека, отговорен за тяхната безопасност. Не се разрешава употребата на този продукт или играта с него от деца.

**CZ: Varování**

Použití tohoto výrobku vyžaduje zkušenosti a znalosti výrobku. Osobám s omezenou fyzickou nebo duševní způsobilostí je zakázáno používat výrobek, výjimkou může být tato osoba, která je pod dohledem osoby zodpovědné za bezpečnost a byla řádně vyškolená na obsluhu tohoto výrobku. Děti nesmí obsluhovat, ani hrát si s tímto výrobkem.

**DK: Advarsel**

Brug af dette produkt kræver erfaring med og kendskab til produktet. Produktet må ikke bruges af personer med begrænsede fysiske, sansemæssige eller mentale evner, medmindre disse personer er under opsyn eller oplært i at bruge produktet af en person med ansvar for deres sikkerhed. Børn må ikke bruge eller lege med dette produkt.

**EE: Hoiatus**

Selle toote kasutamise nõuab kogemust ja toote tundmist. Vähenenud kehaliste, sensoorsete või mentaalsete võimetega inimesed ei tohi seda toodet kasutada, väljaarvatud juhul, kui nad on järelvalve all või nende ohutuse eest vastutav isik on neid instrueerinud toote kasutamiseks. Lapsed ei tohi seda toodet kasutada või mängida selle tootega.

**GR: Προειδοποίηση**

Η χρήση αυτού του προϊόντος απαιτεί σχετική εμπειρία και γνώση του προϊόντος. Άτομα με μειωμένες φυσικές, αισθητικές ή πνευματικές ικανότητες δεν πρέπει να χρησιμοποιούν αυτό το προϊόν, εκτός αν είναι υπό επίβλεψη, ή έχουν καθοδηγηθεί για τη χρήση αυτού του προϊόντος από άτομο υπεύθυνο για την ασφάλειά τους. Παιδιά δεν πρέπει να παίζουν ή να χρησιμοποιούν αυτό το προϊόν.

**ES: Aviso**

La utilización de este producto requiere experiencia y conocimiento sobre el mismo. Este producto no debe ser utilizado por personas con capacidades físicas, sensoriales o mentales reducidas, a menos que lo hagan bajo supervisión o hayan recibido instrucciones sobre el uso de este producto de una persona responsable de su seguridad. Los niños no pueden utilizar o jugar con este producto.

**FR: Avertissement**

L'utilisation de ce produit réclame une certaine expérience et connaissance du produit. Toute personne ayant des capacités physiques, sensorielles ou mentales réduites n'est pas autorisée à utiliser ce produit, à moins qu'elle ne soit surveillée ou qu'elle ait été formée à l'utilisation du produit par une personne responsable de sa sécurité. Les enfants ne sont pas autorisés à utiliser ce produit ni à jouer avec.

**HR: Upozorenje**

Korištenje ovog proizvoda zahtijeva iskustvo i poznavanje proizvoda. Osobe sa smanjenim fizičkim, osjetilnim ili mentalnim sposobnostima ne smiju koristiti ovaj proizvod, osim ako su pod nadzorom ili su poučene o upotrebi ovog proizvoda od osobe odgovorne za njihovu sigurnost. Djeca ne smiju koristiti ili se igrati ovim proizvodom.

**IT: Avvertimento**

L'utilizzo di questo prodotto richiede una certa esperienza. Le persone con abilità fisiche, sensoriali o mentali ridotte non devono utilizzare questo prodotto a meno che non siano state istruite o siano sotto la supervisione di un responsabile. I bambini non devono utilizzare o giocare con questo prodotto.

**LV: Brīdinājums**

Lai lietotu šo produktu, jābūt attiecīgai pieredzei un zināšanām par produktu. Šo produktu nedrīkst lietot personas ar ierobežotām fiziskām, sajūtu un garīgām spējām, ja vien tās neuzrauga vai nav apmācījusi lietot šo produktu par viņu drošību atbildīga persona. Bērni nedrīkst lietot šo produktu vai rotaļāties ar to.

**LT: Įspėjimas**

Šio produkto naudojimas reikalauja patirties ir žinių apie produktą. Draudžiama naudoti šį produktą asmenims su sumažėjusiais fiziniais, sensoriniais ar protiniais gebėjimais, jei jie nėra prižiūrimi arba apmokyti asmens, atsakingo už jų saugumą. Draudžiama vaikams šį produktą naudoti arba su juo žaisti.

**HU: Figyelmeztetés**

A termék használatához termékismeret és tapasztalat szükséges. Csökkent fizikális, mentális vagy érzékelési képességekkel rendelkező személyeknek tilos a termék használata, hacsak hozzá értő személy felügyelet alatt nincsenek, vagy egy a biztonságukért felelős személy által ki nem lettek képezve a termék használatára. Gyermekek nem használhatják és nem játszhatnak ezzel a termékkel.

**NL: Waarschuwing**

Het gebruik van dit product vereist ervaring met en kennis van het product. Personen met verminderde lichamelijke, zintuigelijke of geestelijke vermogens mogen dit product niet gebruiken, tenzij ze onder supervisie staan of instructies hebben gekregen over het gebruik van dit product van een persoon die verantwoordelijk is voor hun veiligheid. Kinderen mogen dit product niet gebruiken of ermee spelen.

**UA: Попередження**

Експлуатація даного обладнання має проводитись кваліфікованим персоналом, котрий володіє достатніми знаннями та навичками. Особам з обмеженими фізичними даними, розумовими та психічними вадами, забороняється використовувати дане обладнання, за виключенням коли їх супроводжує відповідальна особа або їм було проведено інструктаж з техніки безпеки. Інструктаж проводить персонал, котрий відповідає за дану особу. Дітям забороняється використовувати дане обладнання.

**PL: Ostrzeżenie**

Użycie tego produktu wymaga doświadczenia i wiedzy o produkcie. Osoby o obniżonych zdolnościach fizycznych, sensorycznych lub umysłowych nie mogą używać tego produktu, chyba że są pod nadzorem lub zostały poinstruowane o zasadach użytkowania produktu przez osoby odpowiedzialne za ich bezpieczeństwo. Dzieciom nie wolno używać tego produktu lub się nim bawić.

**PT: Aviso**

A utilização deste produto requer experiência com o produto e conhecimento do mesmo. Pessoas com capacidades físicas, sensoriais ou mentais reduzidas não devem usar este produto, a menos que estejam sob supervisão ou tenham recebido formação na utilização deste produto pela pessoa responsável pela sua segurança. As crianças não devem utilizar ou brincusul.

**RU: Внимание**

Эксплуатация данного оборудования должна производиться персоналом, владеющим необходимыми для этого знаниями и опытом работы. Лица с ограниченными физическими, умственными возможностями, с ограниченными зрением и слухом не должны допускаться к эксплуатации данного оборудования без сопровождения или без инструктажа по технике безопасности. Инструктаж должен проводиться персоналом, ответственным за безопасность указанных лиц. Доступ детей к данному оборудованию запрещен.

**RO: Avertizare**

Utilizarea acestui produs necesită experiență de lucru cu produsul și cunoașterea produsului. Este interzisă utilizarea produsului de către persoanele cu capacități fizice, senzoriale sau mentale reduce, cu excepția cazurilor în care acestea sunt supravegheate sau au fost instruite cu privire la utilizarea produsului de către o persoană responsabilă de siguranța lor. Copiii trebuie supravegheați pentru a nu utiliza și a nu se juca cu produsul.

**SK: Upozornenie**

Na používanie tohoto výrobku je potrebné mať príslušnú kvalifikáciu a skúsenosti. Osobám s obmedzenou fyzickou alebo duševnou spôsobilosťou je zakázané používať výrobok, výnimkou môže byť takáto osoba, ktorá je pod dohľadom osoby zodpovednej za jej bezpečnosť a bola riadne vyškolená na obsluhu tohto výrobku. Deti nesmú obsluhovať a ani hrať sa s výrobkom.

**SI: Opozorilo**

Za uporabo tega proizvoda so potrebne predhodne izkušnje in znanja o proizvodu. Osebe z omejenimi fizičnimi, čutnimi ali mentalnimi sposobnostmi tega proizvoda ne smejo uporabljati, razen če so pod nadzorom oziroma, če so prejele navodila za uporabo proizvoda od osebe, ki je odgovorna za njihovo varnost. Otroci ne smejo uporabljati tega proizvoda ali se igrati z njim.

**RS: Upozorenje**

Korišćenje ovog proizvoda zahteva iskustvo i poznavanje proizvoda. Osobe sa smanjenim fizičkim, osetnim ili mentalnim sposobnostima ne smeju koristiti ovaj proizvod, osim ako su pod nadzorom ili su podučene o upotrebi ovog proizvoda od strane osobe odgovorne za njihovu sigurnost. Deca ne smeju koristiti ili se igrati ovim proizvodom.

**FI: Varoitus**

Tämän tuotteen käyttö vaatii kokemusta ja tuotetuntemusta. Henkilöt, joiden fyysinen, aisti- tai henkinen kapasiteetti on heikentynyt, eivät saa käyttää tätä tuotetta muuten kuin valvonnan alaisina tai heidän turvallisuudestaan vastaavan henkilön antamien ohjeiden mukaisesti. Lapset eivät saa käyttää tätä tuotetta tai leikkiä sillä.

**SE: Varning**

Användning av denna produkt kräver erfarenhet och kunskap om produkten. Personer med nedsatt fysisk, sensorisk eller mental förmåga får inte använda denna produkt, såvida de inte är under uppsikt eller har fått utbildning i att använda produkten av en person med ansvar för deras säkerhet. Barn får inte använda eller leka med den här produkten.

**TR: Uyarı**

Bu ürünü kullanabilmek için ürün hakkında bilgili ve deneyimli olmak gereklidir. Fiziksel, duyasak veya algısal yetenekleri az olan kişiler güvenliklerinden sorumlu bir kişi tarafından ürün anlatılmadığı veya bir gözetmen altında olmadan bu ürünü kullanmamalıdır. Çocuklar bu ürünle oynamamalı ve kullanmamalıdır.



---

---

---

---

---

---

---

---

---

---

---

---

---

---

---

---

---

---

---

---

**Argentina**

Bombas GRUNDFOS de Argentina S.A.  
Ruta Panamericana, ramal Campana  
Centro Industrial Garín - Esq. Haendel y Mozart  
AR-1619 Garín Pcia. de Buenos Aires  
Pcia. de Buenos Aires  
Phone: +54-3327 414 444

**Australia**

GRUNDFOS Pumps Pty. Ltd.  
P.O. Box 2040  
Regency Park  
South Australia 5942  
Phone: +61-8-8461-4611

**Austria**

GRUNDFOS Pumpen Vertrieb Ges.m.b.H.  
Grundfosstraße 2  
A-5082 Grödig/Salzburg  
Tel.: +43-6246-883-0

**Belgium**

N.V. GRUNDFOS Bellux S.A.  
Boomsesteenweg 81-83  
B-2630 Aartselaar  
Tél.: +32-3-870 7300

**Belorussia**

Представительство ГРУНДФОС в Минске  
220123, Минск,  
ул. В. Хоружей, 22, оф. 1105  
Тел.: +(37517) 233 97 65,

**Bosnia/Herzegovina**

GRUNDFOS Sarajevo  
Trg Heroja 16,  
BiH-71000 Sarajevo  
Phone: +387 33 713 290

**Brazil**

BOMBAS GRUNDFOS DO BRASIL  
Av. Humberto de Alencar Castelo Branco, 630  
CEP 09850 - 300  
São Bernardo do Campo - SP  
Phone: +55-11 4393 5533

**Bulgaria**

Grundfos Bulgaria EOOD  
Slatina District, Iztochna Tangenta street no. 100  
BG - 1592 Sofia  
Tel. +359 2 49 22 200

**Canada**

GRUNDFOS Canada Inc.  
2941 Brighton Road  
Oakville, Ontario , L6H 6C9  
Phone: +1-905 829 9533

**China**

GRUNDFOS Pumps (Shanghai) Co. Ltd.  
50/F Maxdo Center No. 8 XingYi Rd.  
Hongqiao development Zone  
Shanghai 200336, PRC  
Phone: +86 21 612 252 22

**Croatia**

GRUNDFOS CROATIA d.o.o.  
Cebini 37, Buzin  
HR-10010 Zagreb  
Phone: +385 1 6595 400

**Czech Republic**

GRUNDFOS s.r.o.  
Čajkovského 21  
779 00 Olomouc  
Phone: +420-585-716 111

**Denmark**

GRUNDFOS DK A/S  
Martin Bachs Vej 3  
DK-8850 Bjerringbro  
Tlf.: +45-87 50 50 50

**Estonia**

GRUNDFOS Pumps Eesti OÜ  
Peterburi tee 92G  
11415 Tallinn  
Tel: + 372 606 1690  
Fax: + 372 606 1691

**Finland**

OY GRUNDFOS Pumput AB  
Mestarintie 11  
FIN-01730 Vantaa  
Phone: +358 207889900

**France**

Pompes GRUNDFOS Distribution SA  
Parc d'Activités de Chesnes  
57, rue de Malacombe  
F-38290 St. Quentin Fallavier (Lyon)  
Tél.: +33-4 74 82 15 15

**Germany**

GRUNDFOS GMBH  
Schlüterstr. 33  
40699 Erkrath  
Tel.: +49-(0) 211 929 69-0  
Telefax: +49-(0) 211 929 69-3799  
e-mail: infoservice@grundfos.de  
Service in Deutschland:  
e-mail: kundendienst@grundfos.de

**Greece**

GRUNDFOS Hellas A.E.B.E.  
20th km. Athinon-Markopoulou Av.  
P.O. Box 71  
GR-19002 Peania  
Phone: +0030-210-66 83 400

**Hong Kong**

GRUNDFOS Pumps (Hong Kong) Ltd.  
Unit 1, Ground floor  
Siu Wai Industrial Centre  
29-33 Wing Hong Street &  
68 King Lam Street, Cheung Sha Wan  
Kowloon  
Phone: +852-27861706 / 27861741

**Hungary**

GRUNDFOS Hungária Kft.,  
Park u. 8  
H-2045 Törökbálint,  
Phone: +36-23 511 110

**India**

GRUNDFOS Pumps India Private Limited  
118 Old Mahabalipuram Road  
Thoraipakkam Chennai 600 096  
Phone: +91-44 2496 6800

**Indonesia**

PT GRUNDFOS Pompa  
Jl. Rawa Sumur III, Blok III / CC-1  
Kawasan Industri, Pulogadung  
Jakarta 13930  
Phone: +62-21-460 6909

**Ireland**

GRUNDFOS (Ireland) Ltd.  
Unit A, Merrywell Business Park  
Ballymount Road Lower  
Dublin 12  
Phone: +353-1-4089 800

**Italy**

GRUNDFOS Pompe Italia S.r.l.  
Via Gran Sasso 4  
I-20060 Truccazzano (Milano)  
Tel.: +39-02-95838112

**Japan**

GRUNDFOS Pumps K.K.  
Gotanda Metalion Bldg., 5F,  
5-21-15, Higashi-gotanda  
Shiagawa-ku, Tokyo 141-0022 Japan  
Phone: +81 35 448 1391

**Korea**

GRUNDFOS Pumps Korea Ltd.  
6th Floor, Aju Building 679-5  
Yeoksam-dong, Kangnam-ku, 135-916  
Seoul, Korea  
Phone: +82-2-5317 600

**Latvia**

SIA GRUNDFOS Pumps Latvia  
Deglava biznesa centrs  
Augusta Deglava ielā 60,  
LV-1035, Rīga,  
Tālr.: + 371 714 9640, 7 149 641

**Lithuania**

GRUNDFOS Pumps UAB  
Smolensko g. 6  
LT-03201 Vilnius  
Tel: + 370 52 395 430

**Malaysia**

GRUNDFOS Pumps Sdn. Bhd.  
7 Jalan Peguam U1/25  
Glenmarie Industrial Park  
40150 Shah Alam, Selangor  
Phone: +60-3-5569 2922

**México**

Bombas GRUNDFOS de México S.A. de C.V.  
Boulevard TLC No. 15  
Parque Industrial Stiva Aeropuerto  
Apodaca, N.L. 66600  
Phone: +52-81-8144 4000

**Netherlands**

GRUNDFOS Netherlands  
Veluwezoom 35  
1326 AE Almere  
Postbus 22015  
1302 CA ALMERE  
Tel.: +31-88-478 6336

**New Zealand**

GRUNDFOS Pumps NZ Ltd.  
17 Beatrice Tinsley Crescent  
North Harbour Industrial Estate  
Albany, Auckland  
Phone: +64-9-415 3240

**Norway**

GRUNDFOS Pumper A/S  
Strømsveien 344  
Postboks 235, Leirdal  
N-1011 Oslo  
Tlf.: +47-22 90 47 00

**Poland**

GRUNDFOS Pompy Sp. z o.o.  
ul. Klonowa 23  
Baranowo k. Poznania  
PL-62-081 Przeźmierowo  
Tel: (+48-61) 650 13 00

**Portugal**

Bombas GRUNDFOS Portugal, S.A.  
Rua Calvet de Magalhães, 241  
Apartado 1079  
P-2770-153 Paço de Arcos  
Tel.: +351-21-440 76 00

**România**

GRUNDFOS Pompe România SRL  
Bd. Biruintei, nr 103  
Pantelimon county Ilfov  
Phone: +40 21 200 4100

**Russia**

ООО Грундфос  
Россия, 109544 Москва, ул.  
Школьная 39  
Тел. (+7) 495 737 30 00, 564 88 00

**Serbia**

GRUNDFOS Predstavništvo  
Beograd  
Dr. Milutina Ivkovića 2a/29  
YU-11000 Beograd  
Phone: +381 11 26 47 877 / 11  
26 47 496

**Singapore**

GRUNDFOS (Singapore)  
Pte. Ltd.  
24 Tuas West Road  
Jurong Town  
Singapore 638381  
Phone: +65-6865 1222

**Slovenia**

GRUNDFOS d.o.o.  
Šlandrova 8b,  
SI-1231 Ljubljana-Črnuče  
Phone: +386 1 568 0610

**South Africa**

GRUNDFOS (PTY) LTD  
Corner Mountjoy and George  
Allen Roads  
Wilbart Ext. 2  
Bedfordview 2008  
Phone: (+27) 11 579 4800

**Spain**

Bombas GRUNDFOS España  
S.A.  
Camino de la Fuentecilla, s/n  
E-28110 Algete (Madrid)  
Tel.: +34-91-848 8800

**Sweden**

GRUNDFOS AB  
Box 333 (Lunnagårdsgatan 6)  
431 24 Mölndal  
Tel.: +46 31 332 23 000

**Switzerland**

GRUNDFOS Pumpen AG  
Bruggacherstrasse 10  
CH-8117 Fällanden/ZH  
Tel.: +41-1-806 8111

**Taiwan**

GRUNDFOS Pumps (Taiwan) Ltd.  
7 Floor, 219 Min-Chuan Road  
Taichung, Taiwan, R.O.C.  
Phone: +886-4-2305 0868

**Thailand**

GRUNDFOS (Thailand) Ltd.  
92 Chaloem Phrakiat Rama 9 Road,  
Dokmai, Pravej, Bangkok 10250  
Phone: +66-2-725 8999

**Turkey**

GRUNDFOS POMPA San. ve Tic. Ltd. Sti.  
Gebze Organize Sanayi Bölgesi  
Ihsan dede Caddesi,  
2. yol 200. Sokak No. 204  
41490 Gebze/ Kocaeli  
Phone: +90 - 262-679 7979

**Ukraine**

ТОВ ГРУНДФОС УКРАЇНА  
01010 Київ, Вул. Московська 86,  
Тел.: (+38 044) 390 40 50

**United Arab Emirates**

GRUNDFOS Gulf Distribution  
P.O. Box 16768  
Jebel Ali Free Zone  
Dubai  
Phone: +971 4 8815 166

**United Kingdom**

GRUNDFOS Pumps Ltd.  
Grovebury Road  
Leighton Buzzard/Beds. LU7 8TL  
Phone: +44-1525-850000

**U.S.A.**

GRUNDFOS Pumps Corporation  
17100 West 118th Terrace  
Olathe, Kansas 66061  
Phone: +1-913-227-3400

**Usbekistan**

Представительство ГРУНДФОС  
в Ташкенте  
700000 Ташкент ул.Усмана  
Носира 1-й  
тупик 5  
Телефон: (3712) 55-68-15



